

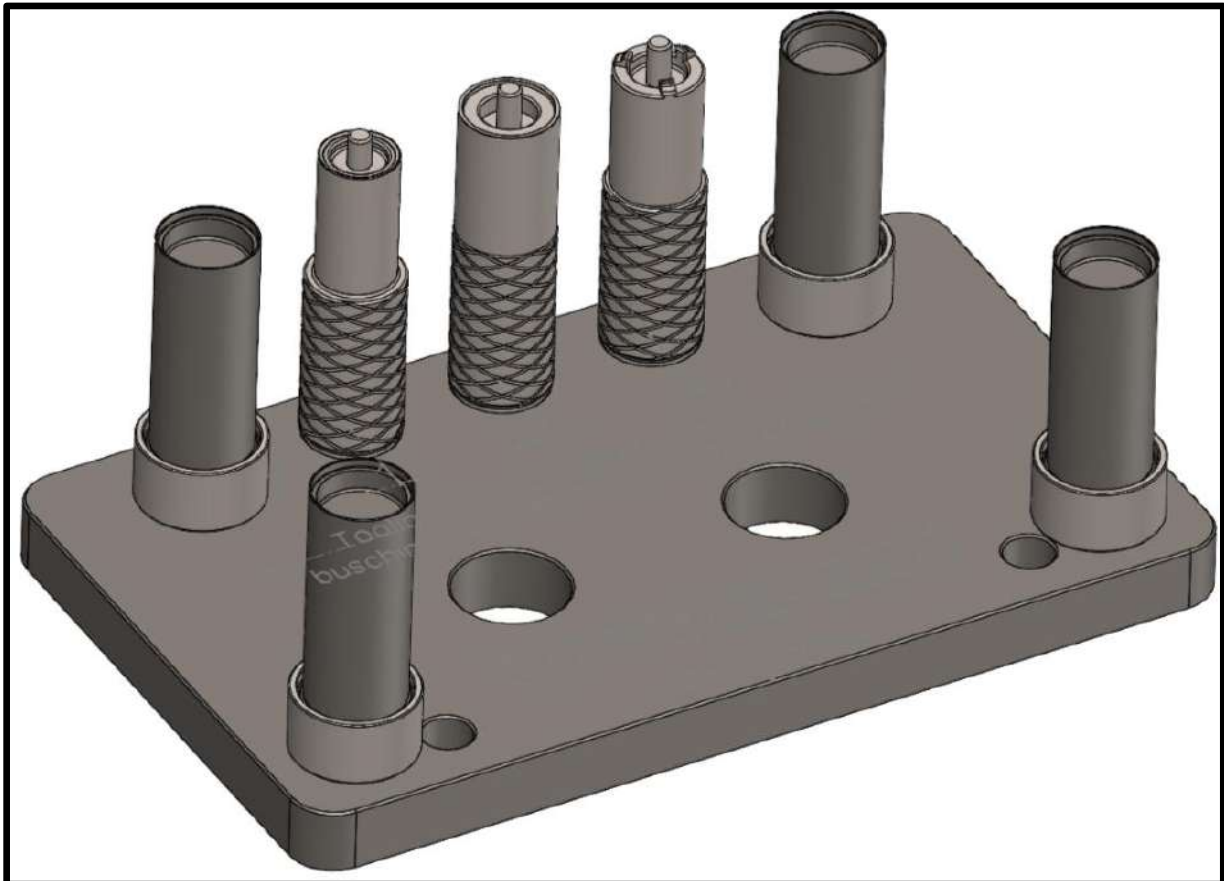

Installation instructions for bushing PR05058P using the tooling O0375



<p>Parts needed:</p>	<p>Tools required:</p>
<p>✓ PR05058P – Rubber bushings for steering wheel air bag retaining frame</p>	<p>✓ O0375 – tooling for bushing set PR05058P</p>

Difficulty level:



Tool:**Tool Components:**

No.	Part number	Name	Quantity
1	31523	Base plate	1
2	31524	Distance support	4
3	31525	Knock-out pin 1.	1
4	31526	Embossing pin 2.	1
5	31527	Deforming pin 3.	1
7	31529	Distance cup	4

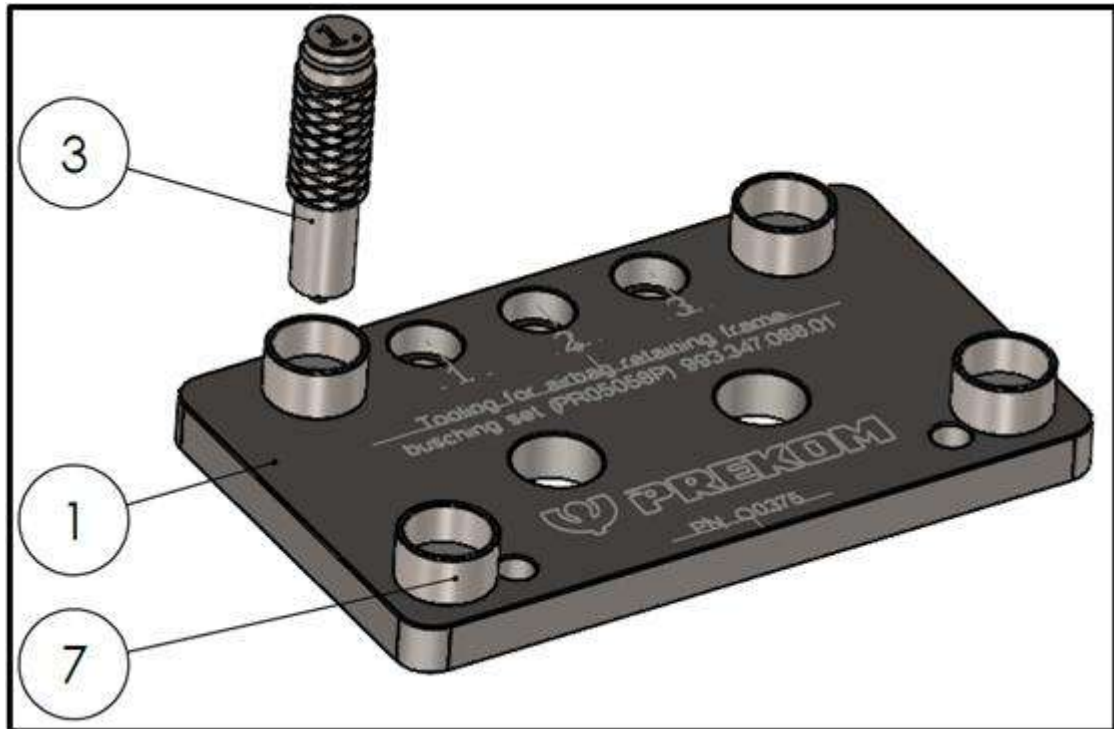
Procedure:**Removal of Old Rubber Bushings:****1. Prepare the Base Plate**

- Place the Base Plate (1) on a stable work surface.
- Attach the Distance Cup (7) onto the Base Plate.

2. Position the Airbag Retaining Frame

- Place the airbag retaining frame onto the Base Plate so that the bushing sits directly above the Distance Cup.
- Ensure the frame is properly centered and supported.

3. Remove the Old Bushing

- Insert Knock-Out Pin 1 (3) into the bushing opening.
- Using a press or a soft mallet, drive the pin downward to push the old bushing out of the retaining frame.
- Repeat the procedure for all bushings.



Installation of New Rubber Bushings

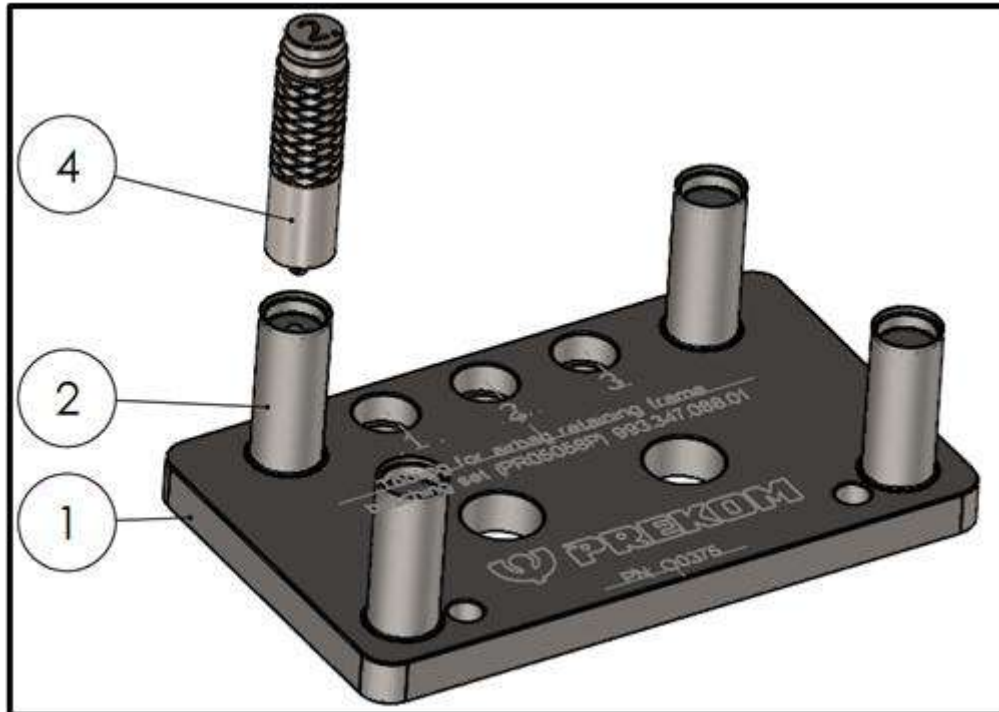

4. Replace the Setup Tools

- Remove the Distance Cup (7) from the Base Plate.
- Install the Distance Supports (2) in its place.

5. Reposition the Retaining Frame

- Place the airbag retaining frame back onto the Base Plate, this time in the opposite orientation (flipped).
- Make sure each bushing seat aligns with the Distance Supports.

6. Press In the New Bushings

- Insert Embossing Pin 2 (4) into the new bushing.
- Press or tap the pin to install the new bushing fully into the frame.
- Repeat for all bushings.



Final Deformation / Locking of the Bushing Housing

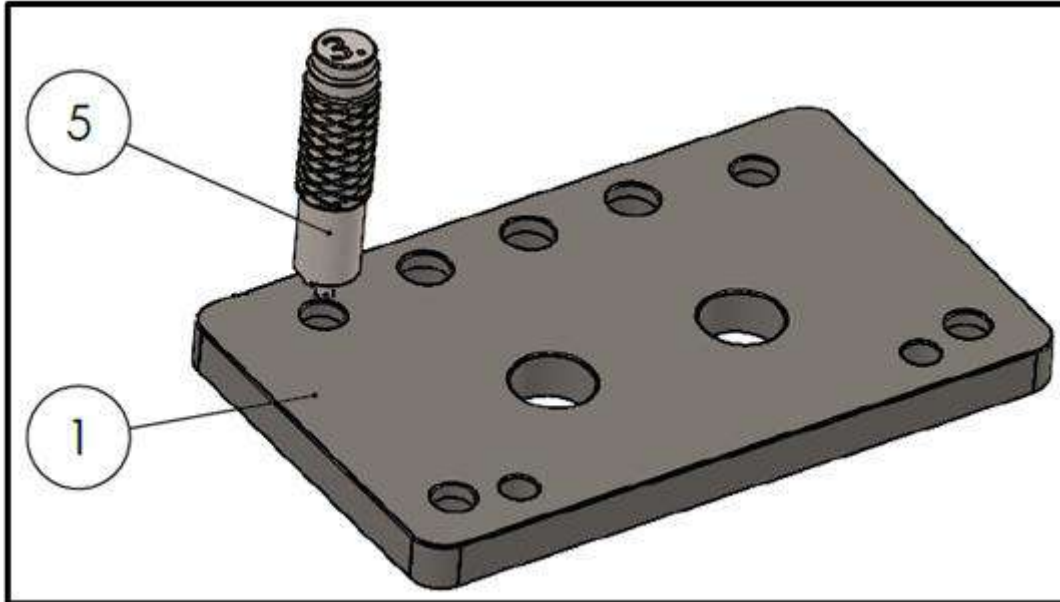

7. Prepare for Final Locking

- Remove all Distance Supports (2) from the Base Plate.
- Rotate the Base Plate (1) so it is positioned for the deformation operation.

8. Lock the Bushing Housing

- Position the retaining frame on the Base Plate.
- Use the Deforming Pin (5) to deform/flare the bushing housing so that the new bushings are securely locked in place.



Completion

After completing all steps:

- ***Verify that each bushing is securely seated and locked.***
- ***Inspect the airbag retaining frame for correct alignment and stability.***



Thank you for your purchase!



www.prekom-usa.com

www.prekom.si



Difficulty level Legend:



- Very Easy (minimal skill required)

- Easy (some skill required)

- Moderate (medium skill required)

- Difficult (experienced installer recommended)

- Very Difficult (professional installation)

The reproduction, distribution and utilization of this document, as well as the communication of its contents to others without explicit authorization is prohibited. Offenders will be held liable for the payment of damages. All rights reserved in the event of the grant of a patent, utility model, or design. (PER ISO 16016).